



### WALL/POLE MOUNT - INTERACTIVE VOICE COMMUNICATION UNIT

The **CB 4-u** is a highly flexible wall or pole mount unit specifically designed for areas that do not have accessible power or phone lines. The **CB 4-u** is available with GSM cellular or IP wireless communication options.

The low power consumption, LED-lit faceplate illuminates the exclusive analog InterAct and VoIP speakerphones designed for maximum reliability, vandal resistance, auxiliary functions, mass notification control, and fault monitoring and reporting capability.

The optional remote mount combination LED beacon/strobe kit provides security with high visibility response to each unit.

With Code Blue's NightCharge® option, the **CB 4-u** can pull power from a switched light grid and operate 24 hours per day, even when the grid is switched off.



#### RATINGS

UL	UL 60950-1 and UL 2017
IP	IP56
NEMA	4X

#### OPTIONAL FEATURES

- ▶ Two-button speakerphone w/keypad
- ▶ Two-button speakerphone
- ▶ NightCharge® with photocell strobe
- ▶ Solar panel array
- ▶ Custom colors and graphics
- ▶ Pole mounting hardware kit
- ▶ Step-down multi-tap power transformer
- ▶ GSM cellular & IP wireless communication
- ▶ Remote mounted combination LED beacon/strobe kit
- ▶ Power over Ethernet

#### STANDARD FEATURES

- ▶ Analog or VoIP speakerphone options
- ▶ ToolVox® compatible with Blue Alert® MNS and Blue Alert EMS
- ▶ IA4100
  - ▶ 2 Inputs - These are simply NO dry contact
  - ▶ 3 Outputs - Can be configured NO or NC
  - ▶ 1 Line Level Audio Output 600 ohm
- ▶ IP5000
  - ▶ 1 input - This is a NO dry contact
  - ▶ 2 Outputs - Each can ONLY be configured NO
  - ▶ 1 Line Level Audio Output 600 ohm
- ▶ 2 Auxiliary inputs/3 Auxiliary outputs (3 NO or 3 NC)
- ▶ LED lit stainless steel faceplate
- ▶ Phone line surge suppressor
- ▶ 24V AC power
- ▶ Voice Identifier
- ▶ ADA compliant
- ▶ Wall mounting kit
- ▶ Vandal resistant hardware
- ▶ Ultra-weather resistant finish



### UNIT SPECIFICATIONS

Overall Height (w/ solar panel)	25.75" (65.4 cm)
Width	14" (35.6 cm)
Depth	12.6875" (32.2 cm)
Housing Material, steel	.125" (0.3cm)
Overall Weight	80 lbs. (36.29 kg)
Power Requirements	24V AC standard input

### UNIT FINISH COLORS

Standard Painted Finish	British Racing Green, Cardinal Red, Dark Bronze, Gloss White, Gloss Black, Medium Bronze, Midnight Blue, Safety Blue, Safety Red, Safety Yellow, Tiger Orange, Bright Silver
Custom Painted Finish	Custom colors from Pantone® color chart or sample are available as a special order

### GRAPHICS TEXT (WORDING)

Standard	Assistance, Courtesy, Emergency, Police, Security, Information, Help Point
Custom	Custom text graphics are available as a special order

### GRAPHICS TEXT COLORS

Standard (reflective decal)	Black, Blue, Green, Red, White, Yellow
Custom	Custom colors from Pantone color chart or sample are available as a special order

### SOLAR POWER

Provides continuous power to the CB 4-u from a solar array without additional power requirements. Allows installation where power lines are not available or cost prohibitive. Requires daytime solar energy.

### REMOTE MOUNT COMBINATION LED BEACON/STROBE

The remote mount allows optimal placement providing a highly visual constant blue beacon and a powerful activated LED strobe for rapid unit location recognition.

### FACEPLATE OPTIONS

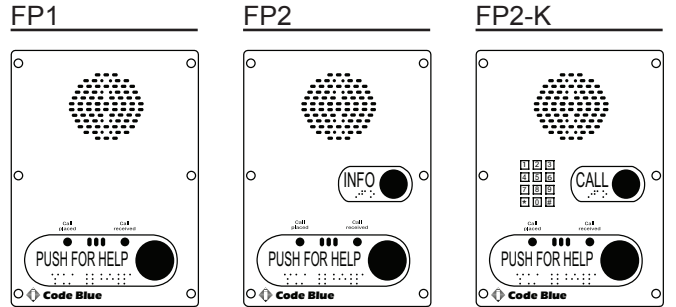

Standard faceplate assembly with single red **PUSH FOR HELP** button

Optional faceplate assembly with additional black **INFO** button

Optional faceplate assembly with additional **CALL** button and keypad

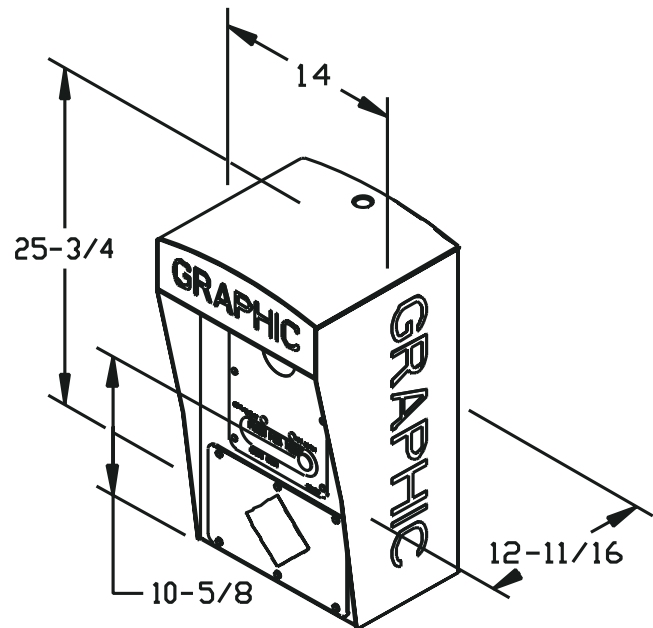

### NIGHTCHARGE® POWER OPTION

Provides continuous power to the unit from a non-continuous power source. Typically used with an outdoor lighting network when power is only on during a portion of the day or night.

- Mounting hardware and template for unit is shipped in advance for foundation work.
- Specifications subject to change without notice or obligation on the part of the manufacturer.