



### RATINGS

UL	UL 60950-1 and UL 2017
IP	IP56
NEMA	4X



CB 1-w with optional WindAssist wind generator

### OPTIONAL FEATURES

- ▶ Two-button speakerphone w/keypad
- ▶ Two-button speakerphone
- ▶ WindAssist™ power generator
- ▶ GSM communication options
- ▶ Custom colors and graphics

### PEDESTAL - INTERACTIVE VOICE COMMUNICATION UNIT

The **CB 1-w** solar/cellular/IP wireless unit continues the standard for rugged reliability set by Code Blue and provides a fully self-contained emergency communication device where power and phone lines are not available. The added costs of trenching are eliminated.

Power for the **CB 1-w** is generated by the vandal resistant, top-mounted solar array and is configured for optimum performance and reliability in almost any geographic location.

The optional WindAssist™ power generator supplements the solar array and provides additional battery charging capacity for areas with intermittent solar availability.

The solar/cellular **CB 1-w** includes either the exclusive analog InterAct and VoIP speakerphones for optimal user programmability, vandal resistance, fault monitoring and reporting functionality, utilizing the most advanced technology in today's industry. Other standard offerings include a low-power consumption lighted faceplate and the combination LED beacon/strobe.

### STANDARD FEATURES

- ▶ Analog and VoIP speakerphone options
- ▶ ToolVox® compatible with Blue Alert® MNS and Blue Alert EMS
- ▶ IA4100
  - ▶ 2 Inputs - These are simply NO dry contact
  - ▶ 3 Outputs - Can be configured NO or NC
  - ▶ 1 Line Level Audio Output 600 ohm
- ▶ IP5000
  - ▶ 1 input - This is a NO dry contact
  - ▶ 2 Outputs - Each can ONLY be configured NO
  - ▶ 1 Line Level Audio Output 600 ohm
- ▶ 2 Auxiliary inputs/3 Auxiliary outputs (3 NO or 3 NC)
- ▶ High output combo LED beacon/strobe
- ▶ LED lit stainless steel faceplate
- ▶ GSM cellular communication
- ▶ Top-mounted solar array
- ▶ Voice Identifier
- ▶ ADA compliant
- ▶ UV resistant lenses
- ▶ Vandal resistant hardware
- ▶ Ultra-weather resistant finish
- ▶ Internal foundation anchor kit
- ▶ Lift eye hook for easy installation
- ▶ 12 standard finish colors



### UNIT SPECIFICATIONS

Overall Height (w/ solar panel)	117" (297.2 cm)
Overall Height (w/ WindAssist)	144" (365.76 cm)
Outside Diameter	12.75" (32.38 cm)
Housing Material, steel	.25" (.635 cm)
Access Opening (w x h)	14" x 9.64" (35.56 x 24.49 cm)
Overall Weight	400 lbs. (181.44 kg)
Power Requirements	Solar powered (standard) WindAssist generator (optional)

### UNIT FINISH COLORS

Standard Painted Finish	British Racing Green, Cardinal Red, Dark Bronze, Gloss White, Gloss Black, Medium Bronze, Midnight Blue, Safety Blue, Safety Red, Safety Yellow, Tiger Orange, Bright Silver
Custom Painted Finish	Custom colors from Pantone® color chart or sample are available as a special order

### GRAPHICS TEXT (WORDING)

Standard	Assistance, Courtesy, Emergency, Police, Security, Information, Help Point
Custom	Custom text graphics are available as a special order

### GRAPHICS TEXT COLORS

Standard (reflective decal)	Black, Blue, Green, Red, White, Yellow
Custom	Custom colors from Pantone color chart or sample are available as a special order

### GSM CELLULAR OPTION

Provides wireless communications to eliminate trenching for phone lines. System requires a reliable GSM cellular service to be provided by customer.

### WINDASSIST™ POWER GENERATOR OPTION

Turbine functioning option for supplemental power provides additional battery charging capacity when intermittent solar availability is a concern. Requires an open area for installation.

### FACEPLATE OPTIONS

FP1	FP2	FP2-K
Standard faceplate assembly with single red <b>PUSH FOR HELP</b> button	Optional faceplate assembly with additional black <b>INFO</b> button	Optional faceplate assembly with additional <b>CALL</b> button and keypad

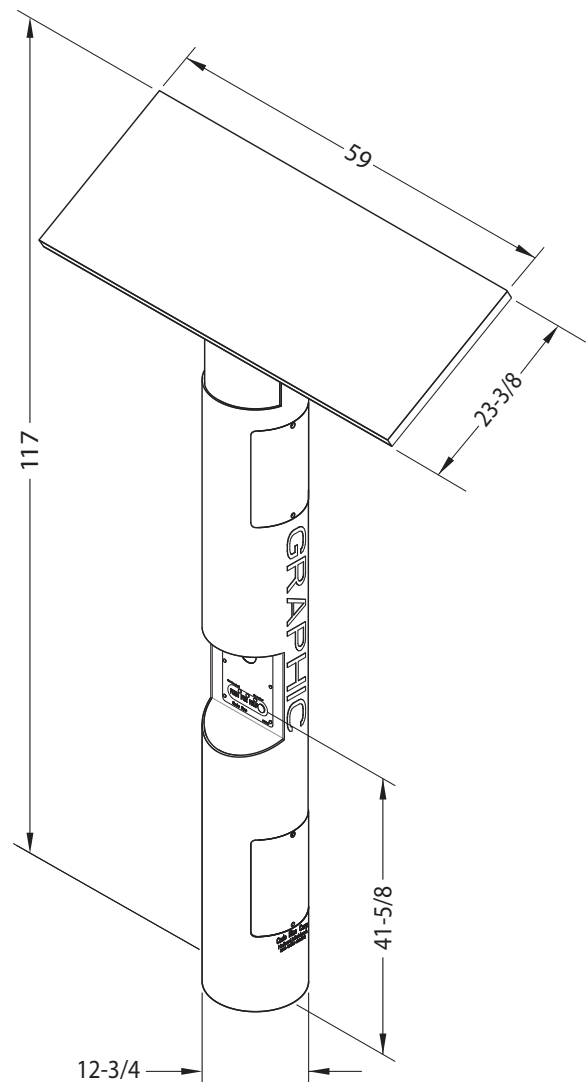

- Mounting hardware and template for unit is shipped in advance for foundation work.
- Specifications subject to change without notice or obligation on the part of the manufacturer.