



Product Description

The **CB 2-e** is Code Blue's most popular wall mounted Help Point®. Highlighted by a high intensity LED beacon/strobe that provides high visibility and is a deterrent to potential crime, and a hands free emergency speakerphone for direct communication with first responders, it can extend security efforts to parking decks, dorm entrances, hallways and public transit centers.

Standard Features

- ✓ Durable stainless steel construction
- ✓ 12-24V AC/DC power standard
- ✓ Slim design built to ADA Specifications
- ✓ High Intensity LED beacon/strobe
- ✓ Integrated wall-mountable backplate

Popular Upgrades



ToolVox™ XV
Virtual Machine



ToolVox™ XS
Server



Managed Cloud Solutions



Remote Mounted
Strobe



Hearing Loop

Technical Features

Specifications

- **Height:** 29.79" (75.67 cm)
- **Width:** 11.90" (30.23 cm)
- **Depth:** 4" (10.16 cm)
- **Weight:** 28 lbs. (12.7 kg)
- **Material & thickness:** 0.078" stainless steel
- **Standard Power:** 12-24V AC/DC
- **Optional Power:**
 - 120-277V AC
 - PoE

Communication

- **Speakerphone Options**
 - **LS1000/LS2000:** Full Duplex, SIP Compatible VoIP Phone.
 - **IA4100:** Analog full duplex phone.
- **Connection Options**
 - **Hardwired**
 - **Cellular**
 - **IP Wireless**

Lighting

- Beacon/strobe

Style

- **Standard wet coat paint options:**

Safety Blue, Safety Yellow, Safety Red, Gloss White, Bright Silver, Tiger Orange, Midnight Blue, Gloss Black, Dark Bronze, Cardinal Red, Medium Bronze, British Racing Green, Architectural Gray, & Oak Buff.

- **Standard Graphics text options:**

Emergency, Assistance, Help Point, Police, Courtesy, Security, Information

- **Standard Graphics text colors:**

White, Black, Blue, Red, Green, Yellow, Orange, Purple, & Brown

Compliance

- UL 62368-1 
- Built to NEMA 4 Specifications
- Designed to ADA Specifications

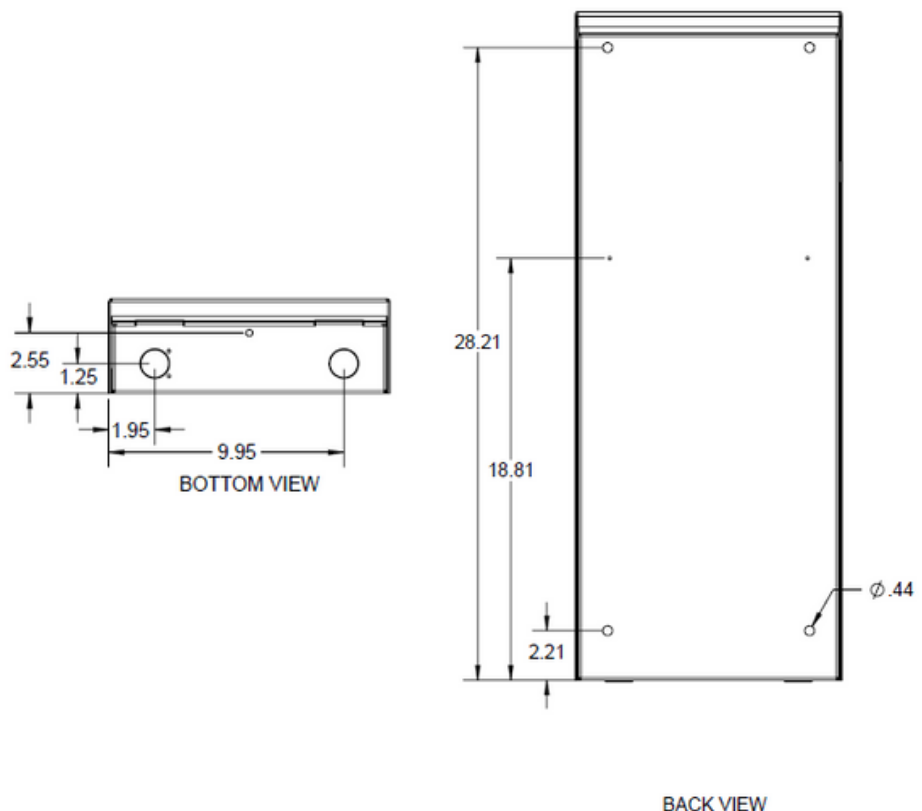
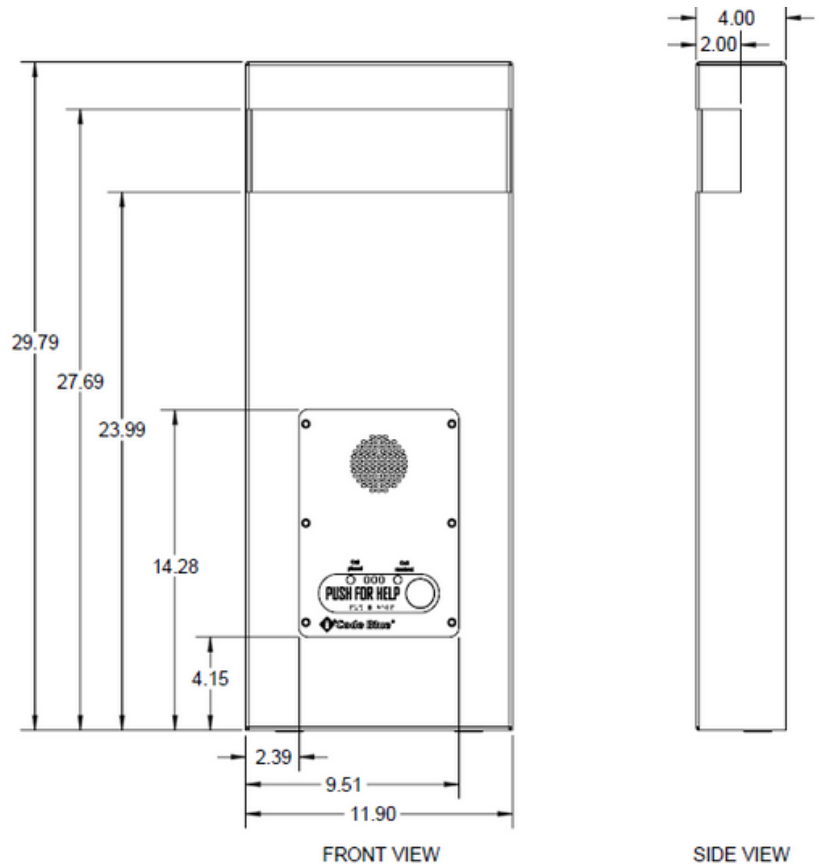

Note: Specifications subject to change without notice or obligation on the part of Code Blue Corporation.