

Product Description

The **CB 1-w** is able to be powered and connected almost anywhere. The high intensity LED beacon/strobe light provides exceptional visibility, giving a presence of public help and this Help Point® acts as a deterrent to potential crime. This blue light emergency tower provides direct communication with first responders and provides optimum performance and reliability in almost any geographic location, including areas where power and phone lines are not available.

Standard Features

- Durable quarter-inch steel construction
- Trademarked cylindrical design
- 9.75 feet tall
- 12.75" diameter
- LED faceplate light
- Solar Photovoltaic (PV) Gel batteries

Optional Features

- Dual faceplate openings
- Hearing loop device
- **New** Solar audio paging

Solar Benefits

- Efficient power delivery even in shady or challenging weather conditions
- Long battery lifecycle and panel life
- Over 2,000 Wh (watt-hours) of energy storage in battery bank
- High efficiency solar cells = maximum power output circuits protected by hydraulic-magnetic breakers to provide protection at extreme temperatures

Popular Accessory

new **Solar Audio Paging Unit**



SIA's Emergency & Mass Communication Systems Honorable Mention 2023 (SIA's New Product Solutions Awards)

Connectivity

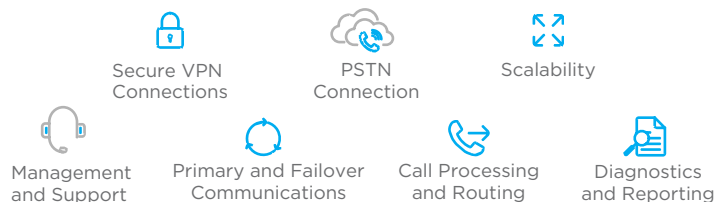

Technical Features



↔ Pedestal Specifications

- **Height:** 9.98' (304.19 cm)
- **Weight:** 400lbs (181.44 kg)
- **Diameter:** 12.75" (32.38 cm)
- **Material:** 0.25" steel
- **Access doors:** 14.00"x9.64"
(35.56 x 24.49 cm)
- **Standard Power:** 12V DC Solar

📶 Communication

- **Speakerphone Options**
 - **LS1000/LS2000:** Full Duplex, SIP Compatible VoIP Phone.
 - **IA4100:** Analog full duplex phone.
- **Connection Options**
 - **Hardwired**
 - **Cellular**
 - **IP Wireless**

☀️ Solar Module

- **Power Output:** 180W
- **Length:** 59.06" (150 cm)
- **Width:** 26.5" (67.5 cm)
- **Depth:** 1.38" (35 mm)
- **Voltage @ Pmax (Vmp):** 19.44 V
- **Max Current (Imp):** 9.26 A
- **Number of cells:** 36
- **Weight:** 26.46 lbs (12.0kg)

💡 Lighting

- LED faceplate light
- Beacon/strobe

🗂️ Style

- **Standard wet coat paint options:** Safety Blue, Safety Yellow, Safety Red, Gloss White, Bright Silver, Tiger Orange, Midnight Blue, Gloss Black, Dark Bronze, Cardinal Red, Medium Bronze, British Racing Green, Architectural Gray, & Oak Buff.
- **Standard Graphics text options:** Emergency, Assistance, Help Point, Police, Courtesy, Security, Information
- **Standard Graphics text colors:** White, Black, Blue, Red, Green, Yellow, Orange, Purple, & Brown

✅ Compliance



- UL 2017
- UL 60950-1
- Built to NEMA 3S Specifications
- Designed to ADA Specifications

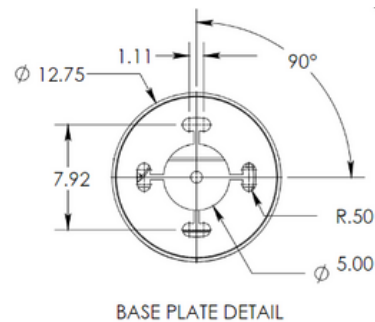
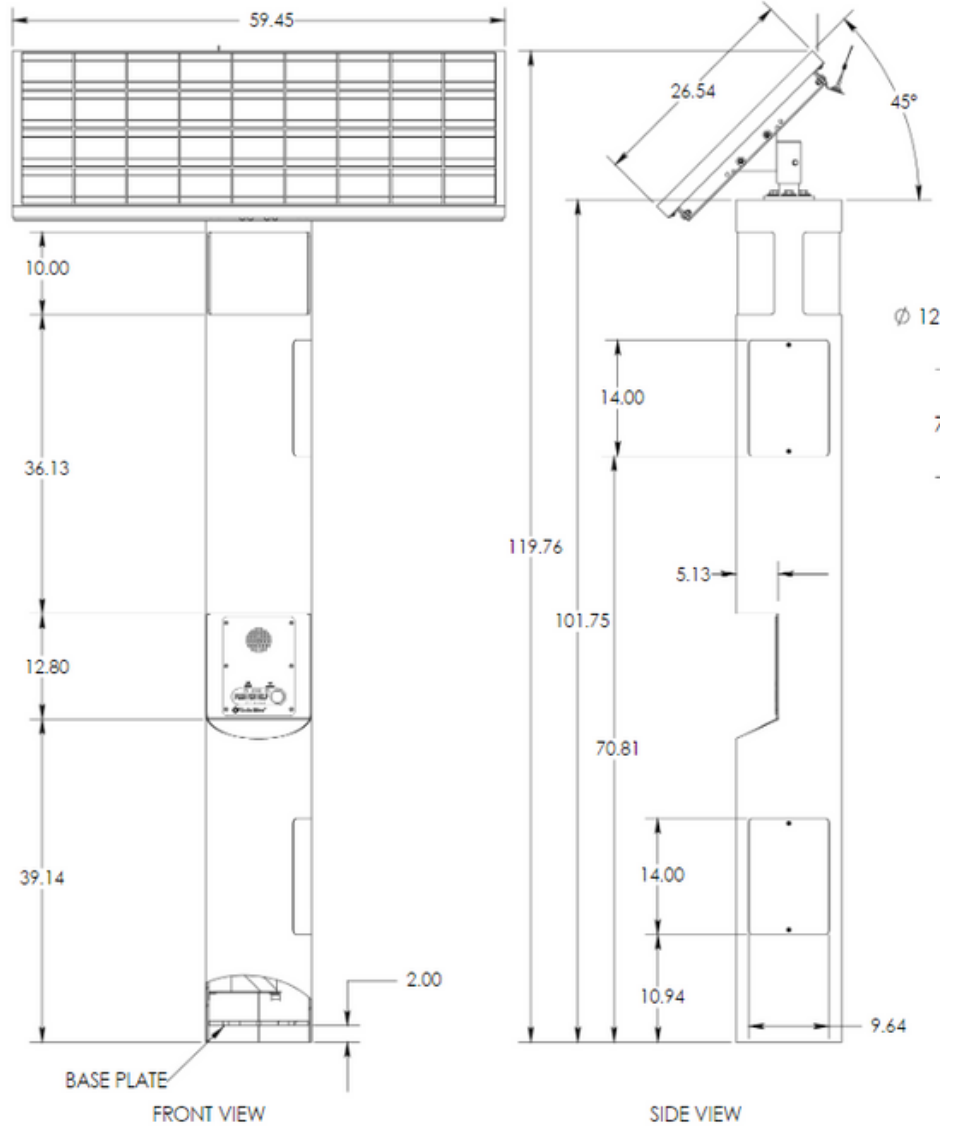

Note: Specifications subject to change without notice or obligation on the part of Code Blue Corporation.