



CB RT Series

Model: ENTM01

Admin Guide

Installation | Configuration | Support | Maintenance | Use



Code Blue[®]

800.205.7186 • www.codeblue.com

WARNING

ONLY QUALIFIED PERSONNEL SHOULD INSTALL THESE UNITS. THE INSTALLATION SHOULD CONFORM TO ALL LOCAL CODES. IN SOME COUNTRIES, A CERTIFIED ELECTRICIAN MAY BE REQUIRED.

NOTICE TO USERS

Copyright © Code Blue Corporation. All rights reserved. This guide or software described herein, in whole or part, shall not be reproduced, translated or reduced to any machine-readable form without prior written approval from Code Blue Corporation.

CODE BLUE CORPORATION PROVIDES NO WARRANTY WITH REGARD TO THIS GUIDE, THE SOFTWARE OR OTHER INFORMATION CONTAINED HEREIN AND HEREBY EXPRESSLY DISCLAIMS ANY IMPLIED WARRANTIES OF MERCHANTABILITY OR FITNESS FOR ANY PARTICULAR PURPOSE WITH REGARD TO THIS GUIDE, THE SOFTWARE OR SUCH OTHER INFORMATION. IN NO EVENT SHALL CODE BLUE CORPORATION BE LIABLE FOR ANY INCIDENTAL, CONSEQUENTIAL, OR SPECIAL DAMAGES, WHETHER BASED ON TORT, CONTRACT, OR OTHERWISE, ARISING OUT OF OR IN CONNECTIONS WITH THIS GUIDE, THE SOFTWARE OR OTHER INFORMATION CONTAINED HEREIN OR THE USE THEREOF.

Code Blue Corporation reserves the right to make any modifications to this guide or the information contained herein at any time without notice. The software described herein may also be governed by the terms of a separate user license agreement.

Code Blue® is a registered trademark of Code Blue Corporation. The names of actual companies and products mentioned herein may be the trademarks of their respective owners.



Table of Contents

Section	Section Title	Page #
2	Introduction	4
	• CB RT Model Photo	4
3	Dimensions	5
3	Safety Information	6
4	Installation Instructions	7
	• Getting Started	7
	• Tools Needed	7
	• CBRT Installation Instructions	8
	◦ Anchor Bolt Installation	8
	◦ Set the Unit	9
	◦ Install Combination Beacon/Strobe	9
	◦ Incoming Power Wiring	9
	• Overhead Camera Mount Installation	10
	• Line Power Installation	11
	• S-1000 & S-1050 Strobe Operation	12
	• S-1000 & S-1050 Strobe Programming	13
5	Power Requirements	14
6	Wiring Diagrams	18
	• CB RT 24-277V AC DIN Rail Power System	18
	• CB RT PoE DIN Rail Power System	19
7	Locating Unit Serial Numbers	20
8	Maintenance Schedule	21
9	Warranty	23
10	Download Information	24
11	Legal & Regulatory Information	25



2 Introduction

Thank you for choosing the **CB RT** for your Code Blue application.

The **CB RT** is an economical pedestal Help Point® highlighted by a high intensity LED beacon/strobe light that provides exceptional visibility and acts as a deterrent to potential crime. This blue light emergency tower provides direct communication with first responders and can extend security efforts to walkways, parking lots, open campus areas and more.

CB RT towers are easily recognized throughout a full 360-degree area. The user friendly lighted faceplate and the integral LED combo strobe ensures rapid location in an open environment and easily identifiable by security when activated. The exclusive analog InterAct and VoIP speakerphones are designed for maximum reliability, vandal resistance, auxiliary functions, mass notification control, and fault monitoring and reporting capability. (See IA4100 or LS1000 guides for more informat guides for more information.)

Our unmistakable craftsmanship makes our Help Points® the most rugged on the market, withstanding the punishment of natural and man-made disasters. With durable construction, our pedestal units can meet any requirement or purpose. **CB RT** tower units have a rugged steel construction, engineering grade reflective graphics and weather, UV and graffiti resistant paint. Lighting with a high-powered, 270 lumens / 92 candela LED blue beacon/strobe.

Other options include:

- IP and analog phones
- Overhead Camera Mount

This guide contains all of the **CB RT** tower information. This manual contains a general overview of the Code Blue **CB RT** Tower options and its application, installation and wiring.



CB RT

3 Dimensions

CB RT

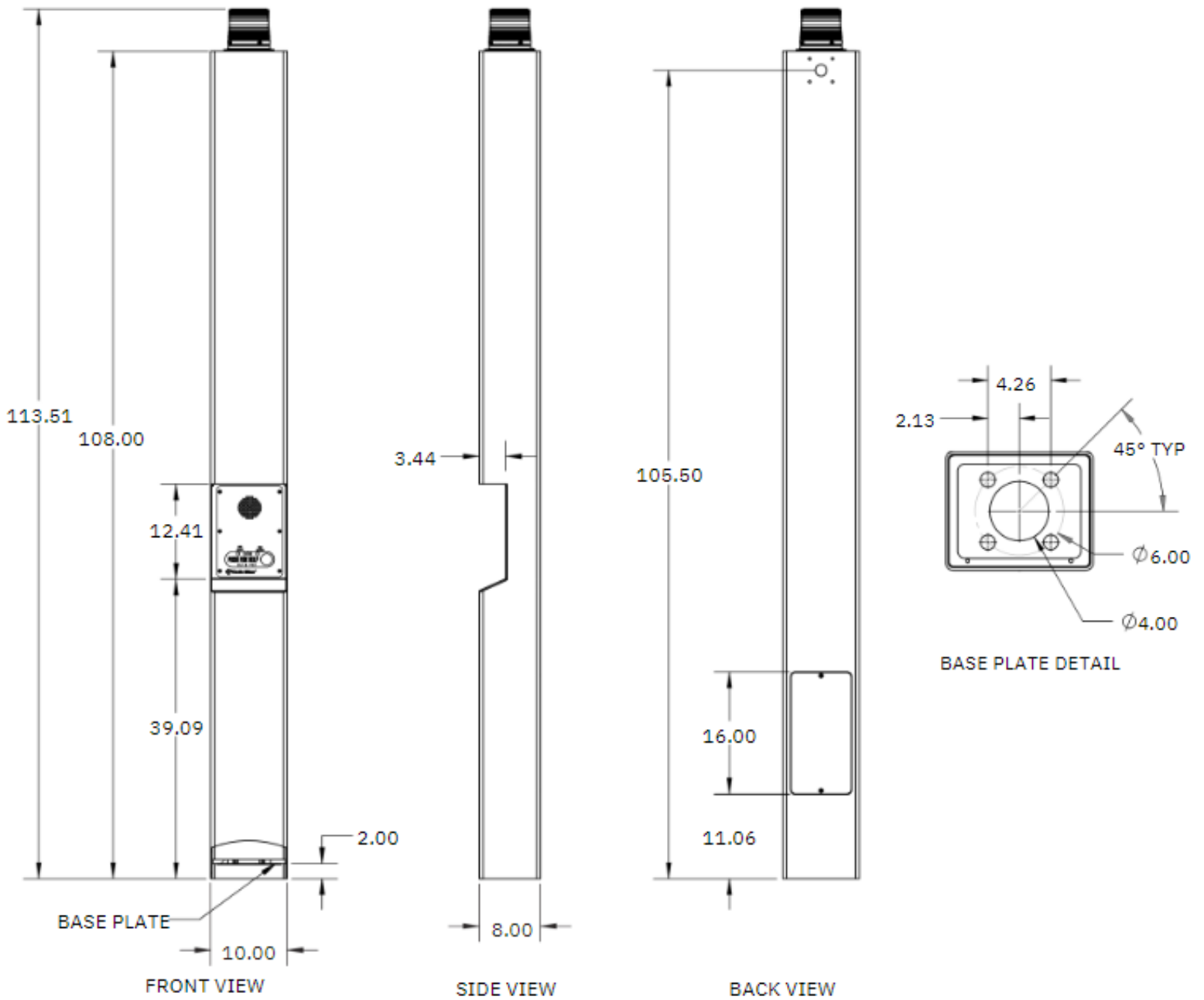



4 Safety Information

HAZARD LEVELS LEGEND

DANGER	Indicates a hazardous situation which, if not avoided, <i>will</i> result in death or serious injury.
WARNING	Indicates a hazardous situation which, if not avoided, <i>could</i> result in death or serious injury.
CAUTION 	Indicates a hazardous situation which, if not avoided, could result in minor or moderate injury.
NOTICE	Indicates a situation which, if not avoided, could result in damage to property.
IMPORTANT	Indicates significant information that is essential for proper product functionality.
NOTE	Indicates useful information that helps get the most out of a product.

Safety Instructions

WARNING • Code Blue products shall be installed by trained professionals. The installation should conform to all local codes. In some countries, a certified electrician may be required.

- NOTICE** • When transporting a Code Blue product, use the original packaging or equivalent to prevent damage to the product.
- Code Blue products shall be used in compliance with local laws and regulations.
 - Store the Code Blue product in a dry and ventilated environment.
 - Do not install the product on unstable brackets, surfaces or walls.
 - Use only applicable tools when installing Code Blue products.
 - Do not use chemicals, caustic agents, steel wool or aerosol cleaners other than those tested and recommended by Code Blue.
 - Use only accessories that comply with technical specifications of the product. These can be provided by Code Blue or a third party.
 - Use only spare/replacement parts provided by or recommended by Code Blue.

Transportation

NOTICE • When transporting a Code Blue product, use the original packaging or equivalent to prevent damage to the product.



5 Installation Instructions

Getting Started

Important Notes:

- EIA/TIA, ANSI, CSA and BICSI cabling or similar standards shall be adhered to for proper operation of Code Blue communication devices connected to copper or fiber infrastructures communications cable and electrical cable in the same conduit is not an acceptable installation and shall not be supported. Analog phones require a minimum of 23mA for proper operation (26-29mA recommended).
- Each analog speakerphone requires its own phone line or PBX extension. Multiple units shall not be supported.
- Speakerphones require programming before operation. Consult the speakerphone's Administrator Guide for instructions.
- If you are installing IP speakerphones, please read the appropriate manuals and consult with your Network Administrator.
- Size electrical wiring based on length of run.

Tools Needed

All CB RT Units Require:

- Ladder to reach the top of the unit.
- Drill & Security Bit for removing & inserting security screws on phone, dome top, & access door.
- 1-1/8" Socket set & extension
- Phillips and flat head screwdrivers

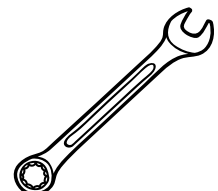
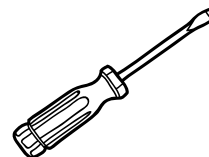
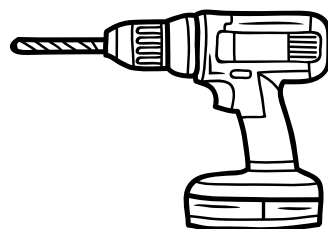



CBRT Installation Instructions

• FOUNDATION - ANCHOR BOLT INSTALLATION INSTRUCTIONS

- **Conduit** – Electrical and communication line conduit should be run through the center of the foundation hole with a maximum combined diameter of three inches. A minimum of four inches and a maximum of six inches of conduit is required above the finished grade level. To ensure proper grounding, a ½-inch x 8-foot copper rod should be inserted in the center of the foundation and tied to the steel enclosure. (Note: Follow all national and local codes governing this installation.)
- **Pour the foundation** – The foundation should be at least 18 inches in diameter and the correct depth for the frost line in your area, with a minimum depth of at least three feet. (Follow your local building codes for foundations.)
- **Set the anchor bolts in the wet foundation** – Four 24-inch L-shaped anchor bolts and an aligning template are supplied for anchoring the unit. The bolts should be set into the foundation so that six inches are showing above the finished grade level. The anchor bolts should be aligned using the supplied template so the faceplate on the unit will face the desired direction.
- **Wiring** – Pull power and phone line up through the conduits. A minimum of two feet of wire must be available from the conduit for electrical and communications wiring.

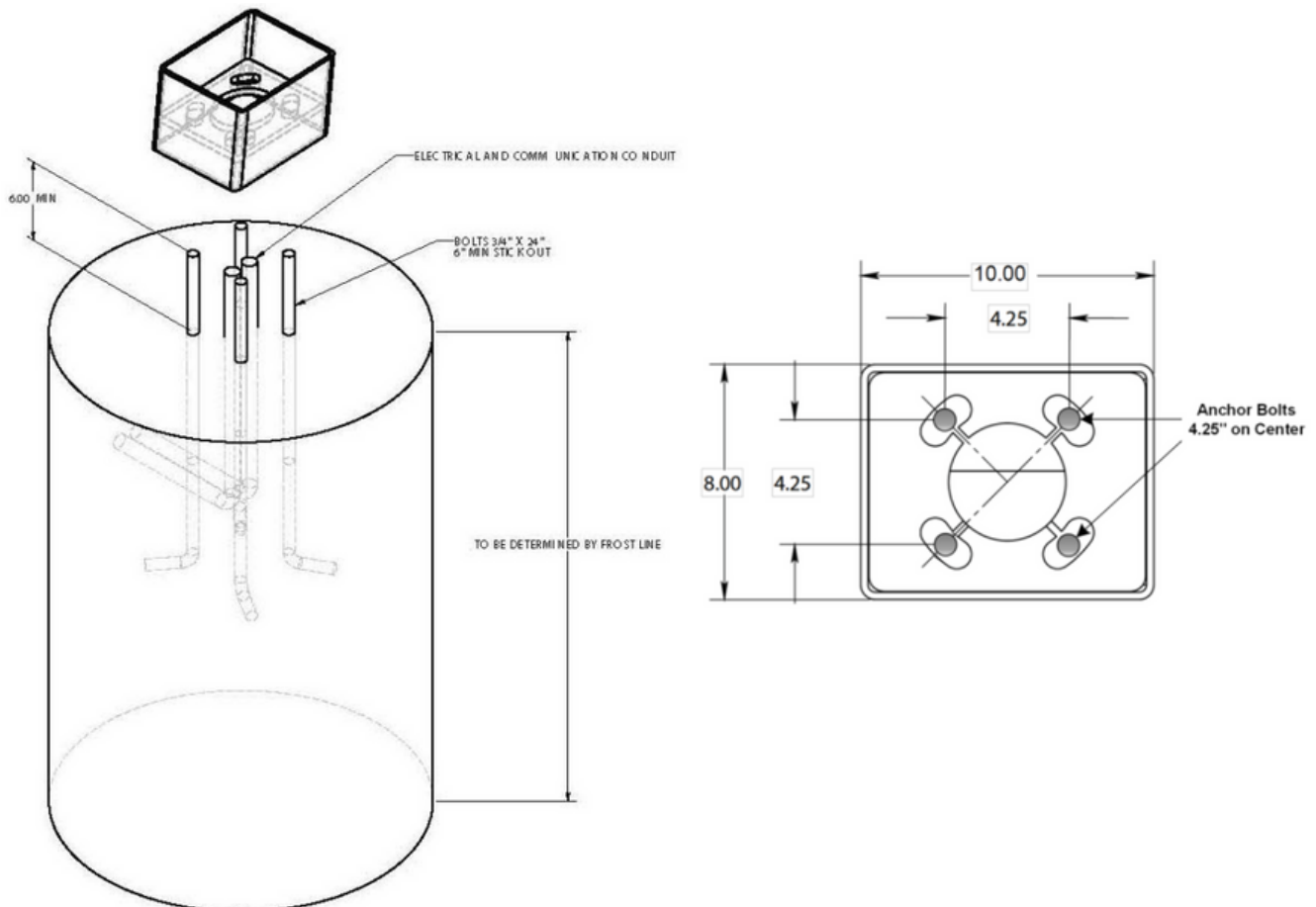



CBRT Installation Instructions (continued)

• SET THE UNIT

- **Screw one set of nuts and washers onto the anchor bolts** – After the foundation has set, screw one set of nuts followed by one set of washers onto the anchor bolts. Set the nuts so the lowest washer is about 2½ inches above the concrete and at an even height. To accomplish this, use a small level and check all three directions. These nuts are not adjustable after the unit is in place. The bottom edge of the unit will be ½-inch above the concrete when installed.

IMPORTANT: The leveling of the bottom nuts is crucial to the leveling of the unit. A small error will be magnified after installation.

IMPORTANT: A ½-inch air gap is required between the foundation and the unit. Moisture problems may result if this condition is not complied with

- **Set the unit on the anchor bolts** – Align the faceplate in the desired direction, then lift the unit over the anchor bolts. Note that the unit weighs approximately 225 pounds. Use appropriate lifting materials and methods to avoid possible injury and/or damage.
 - **Secure the unit** – Access the mounting studs through the door on the side of the unit and tighten the mounting nuts onto the anchor bolts. This may be more convenient if a long socket, extension and universal joint is used to tighten the hardware.
- ### • INSTALL COMBINATION BEACON/STROBE
- **Gasket** – Place the strobe gasket on top of the enclosure.
 - **Connect the cords** – Plug the wires from the beacon-strobe into the mating plug at the top of the enclosure.
 - **Fasten the beacon/strobe** – Using the supplied screws, fasten the beacon-strobe to the top of the enclosure.
- ### • WIRING
- **Ground** – The ground (green) wire should be stripped and fastened to the supplied grounding lug.
 - **24V AC supply** – Using the proper crimping tool, attach a #8 fork to each of the incoming power wires and fasten them to the terminal screws labeled “24V AC.”
 - **120/240V AC supply** – Using the proper crimping tool, attach a #8 fork to each of the incoming power wires and fasten them to the correct terminals as labeled on the transformer. After completing the wire connections, install the supplied terminal covers.

All wiring must be installed and connected by experienced and certified personnel to meet local and national electrical codes, and will include a service disconnect.



Overhead Camera Mount Installation

All CB RT Overhead Camera Mounts Require:

- Ladder to reach the top of the unit.
- 3/8" Wrench

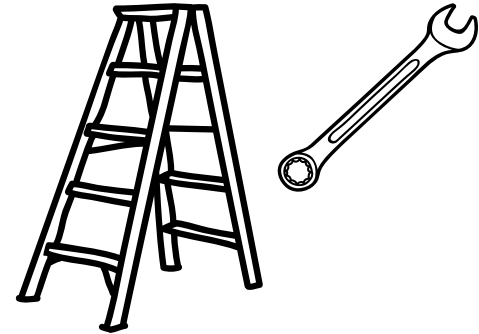

Installing the Overhead Camera Mount

The camera mount will come with a gasket already mounted to the bracket on the arm.

- Place the bracket over the mounting holes and insert the four 3/8-16 X 1 stainless bolts. (The 3/8" stainless steel bolts should have one stainless steel washer and one rubber washer.)
- Verify the camera mount is evenly positioned to ensure the gasket seal is properly seated.
- Tighten the bolts with your 3/8" wrench in a crisscross pattern to ensure even pressure until it is snug against the outside of the enclosure.

Installing the Camera

- Camera and wiring (supplied by others) is installed into the male 1½ NPT.

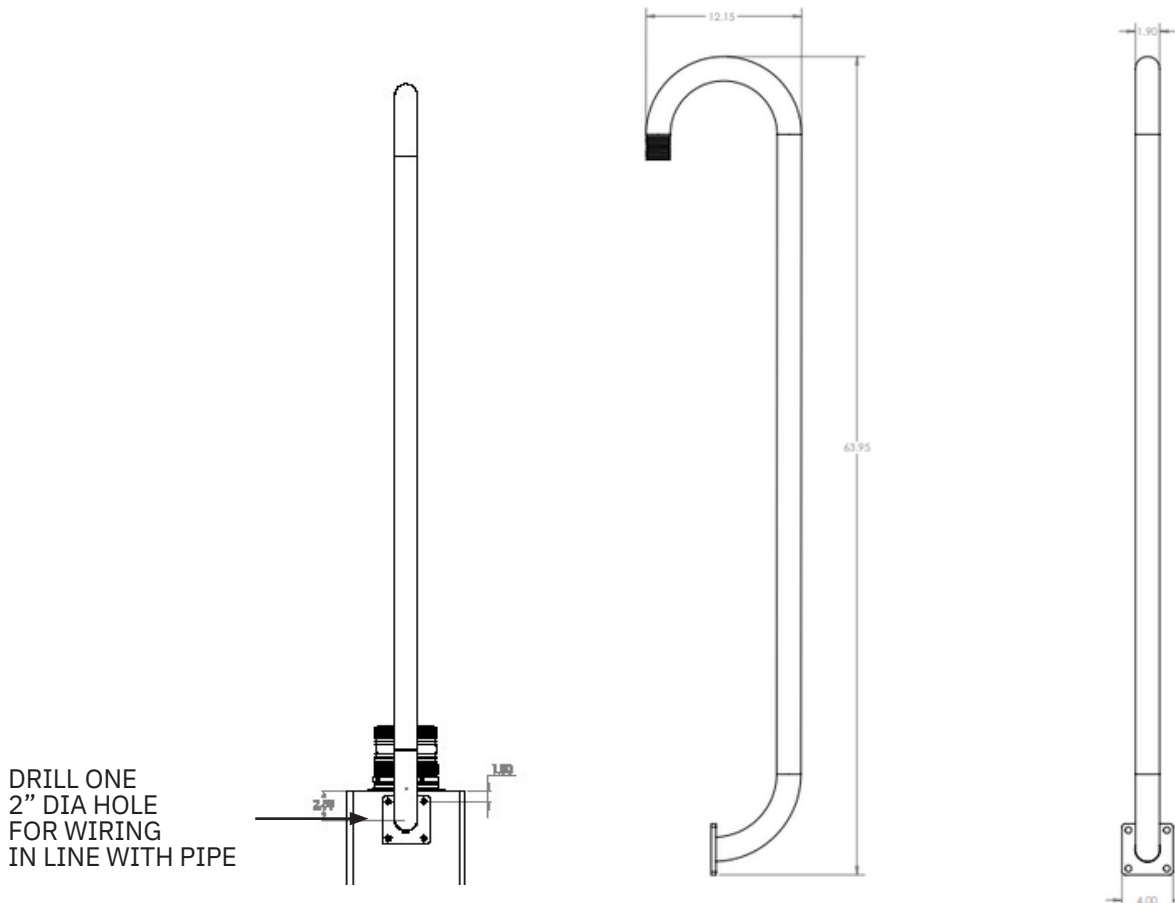

All wiring must be installed and connected by experienced and certified personnel to meet local and national electrical codes, and will include a service disconnect.



Line Power Installation Instructions

IMPORTANT: All wiring shall comply with national and local codes governing this installation. It is the responsibility of the installer to ensure these conditions are complied with.

- **SUPPLY WIRING**

- **Pulling the power wires** – Wire should be a minimum of 14 AWG and be pulled into the unit, leaving a minimum of two feet of wire from the opening of the conduit.
- **Pulling the communications wire** (if needed) – Communications wire must be shielded phone line. The phone line must be pulled into the unit using a separate conduit from the power, and be run so as to extend a minimum of two feet out of the phone opening.

- **CONNECT THE POWER WIRES**

- **Make the connections** – Locate the grounding lug and connect the ground wire.
- **Using 115V AC supply** – Connect the colored (hot) wire to the black wire, and connect the white or gray (neutral) wire to the white wire.
- **Higher voltage supply** – If the unit was ordered for a higher voltage, a pre-wired power brick will be located on the top of the electrical panel with a 24 volt secondary to supply the low voltage manifold and power brick to supply the area light. Connect the colored (hot) wire and the white or gray (neutral) wire to the white wire in the junction box.

- **CONNECT THE PHONE LINE** (if required) – See phone Installation Instructions.

- **APPLY POWER** – The unit should become operational immediately after the power is energized.



S-1000 & S-1050 Strobe Operation

NOTE: Instructions pertain to:
Model S-1000 LED Beacon/Strobe and
Model S-1050 LED Beacon/Strobe only.

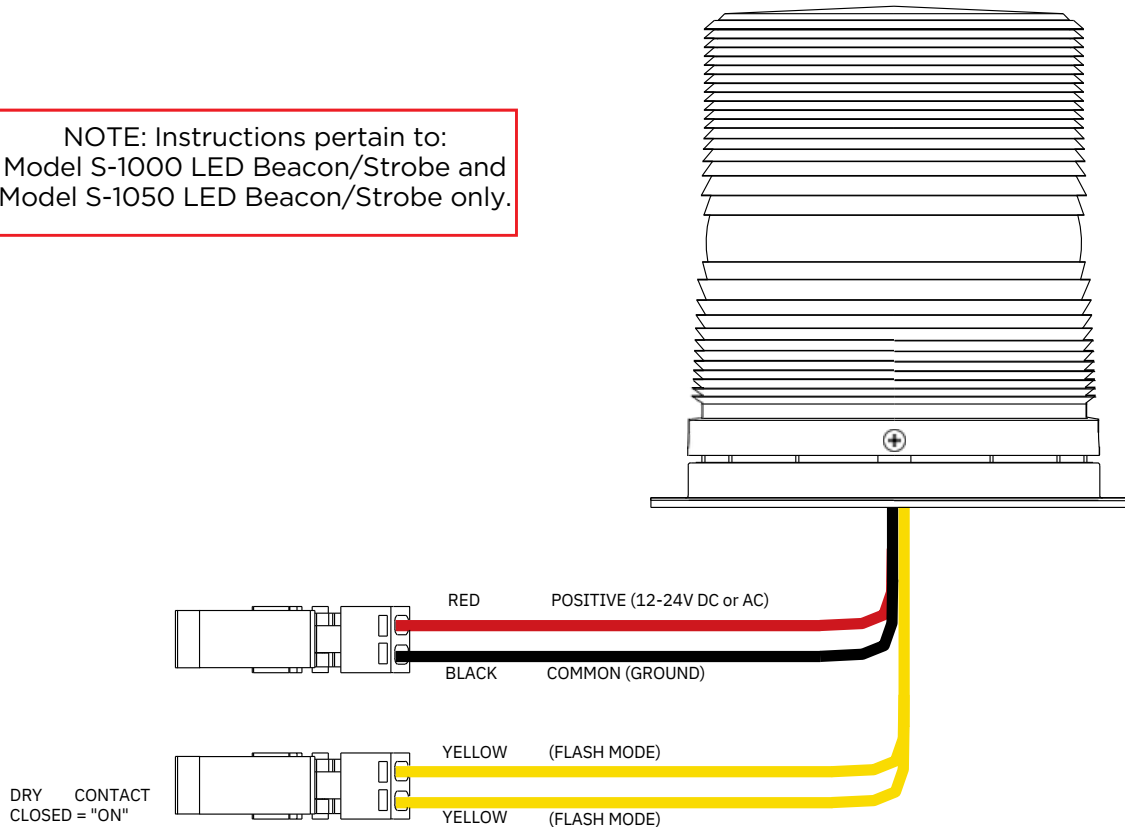

CAUTION ⚠️ **REMOVE ALL POWER FROM UNIT BEFORE SERVICING.**

OPERATION

To activate the LEDs in the PRIMARY-STEADYBURN MODE, connect the BLACK and RED wires to 12-24 volts AC or DC.

When in PRIMARY-STEADYBURN MODE, to change the LEDs to SECONDARY-FLASH MODE, connect both YELLOW control wires together (i.e., CLOSED = ON).

PHOTOCELL FEATURE (S-1050 MODEL)

The Steadyburn Mode will be ON in dark or night ambient environments and OFF in bright or daylight ambient environments. The S-1050 LED Beacon/Strobe has two built-in photo response features: (a) dawn/dusk transition delay of 15-30 minutes and (b) transient light acknowledgement delay of at least 3 minutes.

PROGRAMMING PRIMARY & SECONDARY MODES

1. Remove power from unit.
2. Short the Yellow wires together.
3. Restore power to the unit and wait until the unit begins to flash. Once the unit begins to flash, remove the short. The unit will alternately demonstrate the Secondary-Flash Mode and Primary-Steadyburn Mode that will be displayed during operation. For approximately 4 seconds the Secondary-Flash Mode will be demonstrated, followed by the Primary-Steadyburn Mode.
4. To select the next mode of operation, momentarily short the yellow wires. The unit will cycle to the next mode in the list above.

Mode Number	Primary-Steadyburn Mode	Secondary-Flash Mode
1	High	Single - 60 FPM
2	OFF	Single - 60 FPM
3	Low	Single - 60 FPM
4	High	Single - 150 FPM
5	OFF	Single - 150 FPM
6	Low	Single - 150 FPM
7	High	Single - 375 FPM
8	OFF	Single - 375 FPM
9	Low	Single - 375 FPM
10	High	Neobe - 75
11	OFF	Neobe - 75
12	Low	Neobe - 75
13	High	Neobe - 150
14	OFF	Neobe - 150
15	Low	Neobe - 150
16	High	Double - 125
17	OFF	Double - 125
18	Low	Double - 125
19	High	Double - 250
20	OFF	Double - 250
24	Low	Double - 250

5. There are seven Flash Modes and three Steadyburn Modes combinations to choose from.
6. When you reach the desired mode of operation, remove power from the unit. You MUST leave power disconnected for 20 seconds BEFORE reapplying. When power is reapplied, the unit will operate as programmed above.

NOTE: If you do not leave power disconnected for 20 seconds before reapplying power, the light will default to Program Mode.

INPUT VOLTAGE RANGE: 12-24V AC or DC		
TEMPERATURE RATING: -40°C to +65°C (-40°F to 149°F)		
TYPICAL POWER CONSUMPTION AT 25°C		
Voltage Flash Mode		Steady Mode - High
12V DC	0.24 A Max	0.24 A
24V DC	0.12 A Max	0.12 A
12V AC	1.1 A rms Max	0.53 A rms
24V AC	0.22 A rms Max	0.22 A rms
NOTE: Average current draw in Flash Mode will vary by selected Flash mode. The above maximum amperage draw is stated at Single 60 FPM.		



6 Power Requirements

The following tables on pages 14-17 include **CB RT** and ALL OTHER Code Blue devices & enclosures for reference.

Faceplates	Voltage	Max Current	Max Watts	Norm Current	Norm Watts	KWHrs
IA4100	24V AC	0.40	9.60	0.22	5.28	0.13
	12V DC	0.90	10.80	0.39	4.68	0.11
	24V DC	0.90	21.60	0.39	9.36	0.22
IP5000	24V AC	0.10	2.40	0.07	1.68	0.04
	12V DC	0.19	2.28	0.15	1.80	0.04
	24V DC	0.19	4.56	0.15	3.60	0.09
Centry	12VDC	0.50	6.00	0.38	4.56	0.11
LS1000/LS2000	12V DC	0.50	3.60	0.40	4.80	0.12
Lights	Voltage	Max Current	Max Watts	Norm Current	Norm Watts	KWHrs
s-1000/S-2000 LED Strobe	24V AC	0.28	6.72	0.22	5.28	0.13
	12V DC	0.26	3.12	0.24	2.88	0.07
	24V DC	0.26	6.24	0.24	5.76	0.14
A-700 Area Light	24V AC	1.80	43.20	0.83	19.92	0.48
	12V DC	2.68	32.16	0.38	4.56	0.11
	24V DC	2.68	64.32	0.38	9.12	0.22
S-1050 LED Strobe W/ Photocell	24V AC	0.28	6.72	0.22	5.28	0.13
	12V DC	0.27	3.22	0.24	2.88	0.07
	24V DC	0.27	6.43	0.24	5.76	0.14
LED Light Bar	24V AC	0.04	0.96	0.04	0.96	0.02
	12VDC	0.04	0.48	0.04	0.48	0.01
	24V DC	0.04	0.96	0.04	0.96	0.02
WM180 PAS With LED Strobe	12-24V DC	7.30	175.20	2.10	50.40	1.21



Models With IA4100 Faceplate	Voltage	Current	Watts	KWHrs
CB 1-e	24V AC	0.48	11.52	0.28
	12VDC	0.67	8.04	0.19
	24V DC	0.67	16.08	0.39
CB 1-s	24V AC	1.31	31.44	0.75
	12V DC	1.05	12.60	0.30
	24V DC	1.05	25.20	0.60
CB 5-s	24V AC	0.48	11.52	0.28
	12V DC	0.67	8.04	0.19
	24V DC	0.67	16.08	0.39
CB 9-s	24V AC	0.26	6.24	0.15
	12V DC	0.43	5.16	0.12
	24V DC	0.43	10.32	0.25
CB 2-e	24V AC	0.44	10.56	0.25
	12VDC	0.63	7.56	0.18
	24V DC	0.63	15.12	0.36
CB 2-a	24V AC	0.48	11.52	0.28
	12V DC	0.67	8.04	0.19
	24V DC	0.67	16.08	0.39
CB 2-s	24V AC	1.31	31.44	0.75
	12V DC	1.05	12.60	0.30
	24V DC	1.05	25.20	0.60
CB 2 w/ Audio Paging	12-24V DC	6.44	154.56	3.71
CB 4-s	24V AC	0.22	5.28	0.13
	12V DC	0.39	4.68	0.11
	24V DC	0.39	9.36	0.22
CB 4-r	24V AC	0.26	6.24	0.15
	12V DC	0.43	5.16	0.12
	24V DC	0.43	10.32	0.25
CB 4-u	24V AC	0.26	6.24	0.15
	12V DC	0.43	5.16	0.12
	24V DC	0.43	10.32	0.25
CB 6-F & CB 6-S	24V AC	0.22	5.28	0.13
	12V DC	0.39	4.68	0.11
	24V DC	0.39	9.36	0.22
CB RT	24V AC	0.48	11.52	0.28
	12V DC	0.67	8.04	0.19
	24V DC	0.67	16.08	0.39



Models With IP5000 Faceplate	Voltage	Current	Watts	KWHrs
CB 1-e	24V AC	0.33	7.92	0.19
	12VDC	0.43	5.16	0.12
	24V DC	0.43	10.32	0.25
CB 1-s	24V AC	1.16	27.84	0.67
	12V DC	0.81	9.72	0.23
	24V DC	0.81	19.44	0.47
CB 5-s	24V AC	0.33	792.00	0.19
	12V DC	0.43	5.16	0.12
	24V DC	0.43	10.32	0.25
CB 5-s	24V AC	0.11	2.64	0.06
	12VDC	0.19	2.28	0.05
	24V DC	0.19	4.56	0.11
CB 2-e	24V AC	0.29	6.96	0.17
	12V DC	0.39	4.68	0.11
	24V DC	0.39	9.36	0.22
CB 2-a	24V AC	0.33	7.92	0.19
	12VDC	0.43	5.16	0.12
	24V DC	0.43	10.32	0.25
CB 2-s	24V AC	1.16	27.84	0.67
	12V DC	0.81	9.72	0.23
	24VDC	0.81	19.44	0.47
CB 2 w/ Audio Paging	12-24V DC	6.44	154.56	3.71
CB 4-S	24V AC	0.07	1.68	0.04
	12V DC	0.15	1.80	0.04
	24V DC	0.15	3.60	0.09
CB 4-r	24V AC	0.11	2.64	0.06
	12VDC	0.19	2.28	0.05
	24V DC	0.19	4.56	0.11
CB 4-u	2av AC	0.11	2.64	0.06
	12VDC	0.19	2.28	0.05
	24V DC	0.19	4.56	0.11
CB 6-F & CB 6-S	24VAC	0.07	1.68	0.04
	12V DC	0.15	1.80	0.04
	24V DC	0.15	3.60	0.09
CB RT	24V AC	0.33	7.92	0.19
	12V DC	0.43	5.16	0.12
	24V DC	0.43	10.32	0.25



Models with LS1000/LS2000	Voltage	Current	Watts	KWHrs
CB 1-e	12V DC	0.68	8.16	0.20
CB 1-s	12V DC	1.06	12.72	0.31
CB 5-s	12V DC	0.68	8.16	0.20
CB 9-S	12V DC	0.44	5.28	0.13
CB 2-e	12V DC	0.64	7.68	0.18
CB 2-a	12V DC	0.68	8.16	0.20
CB 2-s	12V DC	1.06	12.72	0.31
CB 4-s	12V DC	0.40	4.80	0.12
CB 4-r	12V DC	0.44	5.28	0.13
CB 4-U	12V DC	0.44	5.28	0.13
CB 6-F & CB 6-S	12V DC	0.40	4.80	0.12
CB RT	12V DC	0.68	8.16	0.20

High Voltage Models	Voltage	Current	Watts	KWHrs
CB 1 w/ Audio Paging	12-24V DC	3.83	460	11
CB 5 w/ Audio Paging	12-24V DC	3.33	400	9.6
CB 1 w/ NightCharge	120V AC	2.5	300	2.4
CB 4-U w/ NightCharge	120V AC	2.5	300	2.4

High Voltage AC Components	Voltage	Current	Watts	KWHrs
Multi-Tap Power Supply	120V AC	1.75A/210VAC	210	5.04
DIN Rail Power Supply	120V AC	1.2A/115VAC	115	2.76
Audio Paging Amp	12-24V DC	3.83	459.6	11.03



7 Wiring Diagrams

CB RT 24-277V AC DIN Rail Power System

For installations with 24-277V AC incoming power on site. Provides flexibility for future power updates.

Used in the following configurations:

- Standard CB RT - No Cellular Communication
- CB RT with Cellular Communication

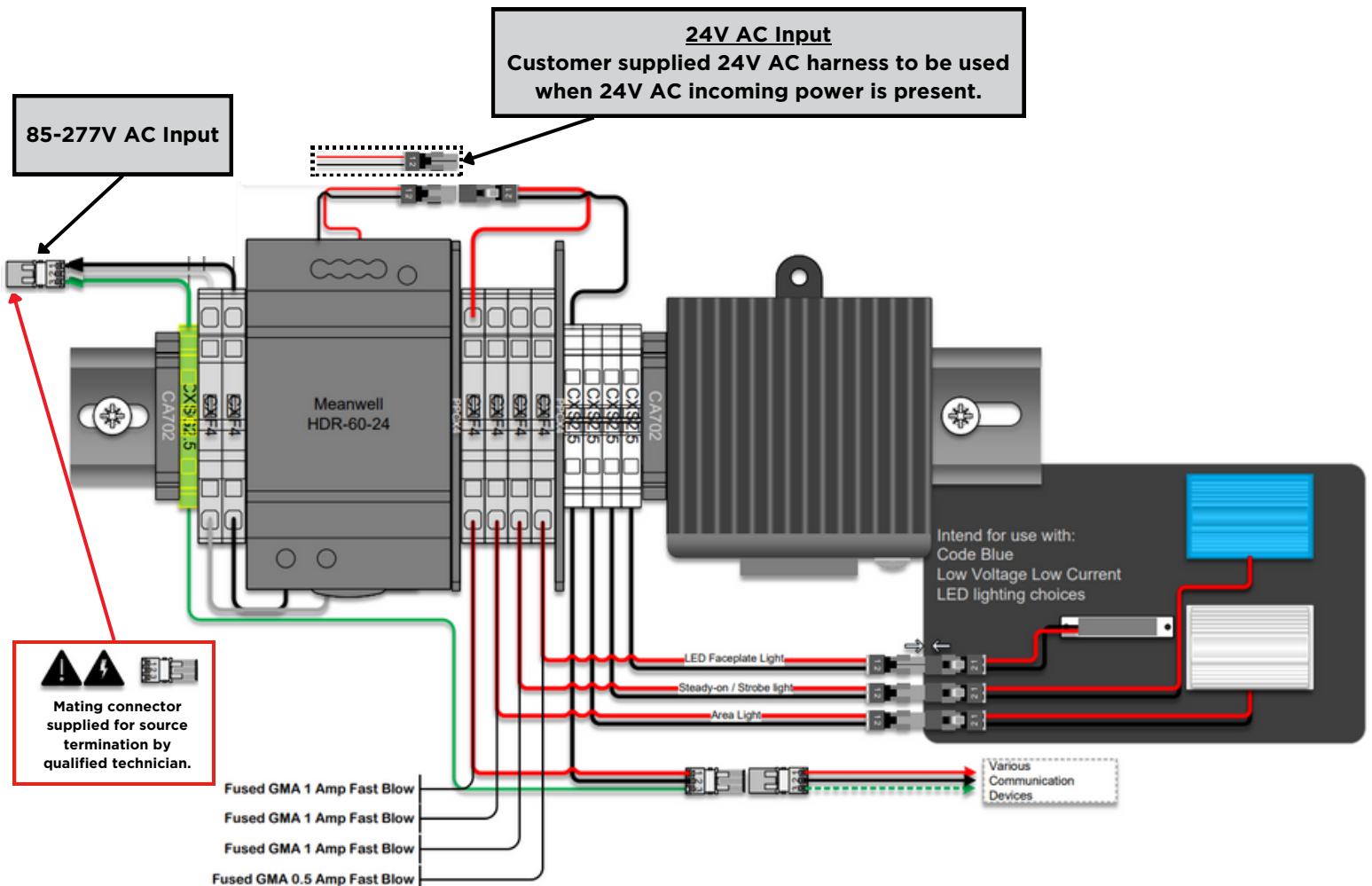

DIN Rail Layout





CB RT PoE DIN Rail Power System

For installations with PoE incoming power on site.

Used in the following configurations:

- Standard CB RT - No Cellular Communication

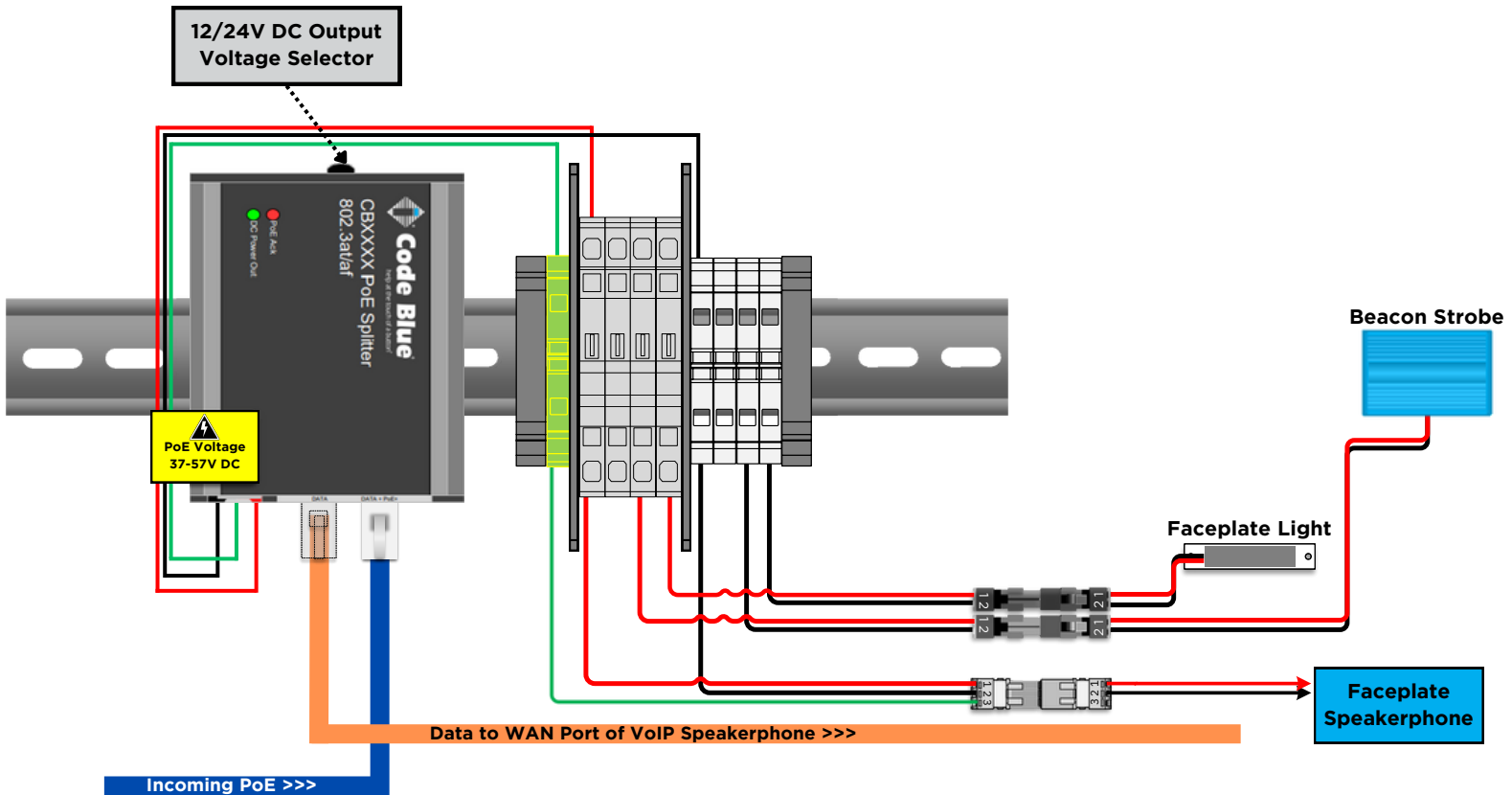

DIN Rail Layout



Order of Connection

1. Connect Lighting & Communication devices to power system via Wago plug & socket connectors.
2. Connect RJ45 ethernet cable (Cat5e or Cat6) from "Data" port on PoE splitter to the WAN port of the VoIP speakerphone.
3. Plug incoming PoE ethernet RJ45 cable (Cat5e or Cat6) into "Data + PoE" port on PoE splitter. Splitter will light up accordingly indicating passing of DC voltage.

IMPORTANT NOTE: LS1000 speakerphones operate on 12V DC only. If the 24V DC output is selected on the PoE splitter, the use of a 24V to 12V DC step-down transformer must be installed prior to connecting the power system to the speakerphone.

8 Locating Unit Serial Numbers

Remove the access plate cover with the special security bit. The serial number will be listed on the manufacturer's label located on the backside of the access plate cover (1).

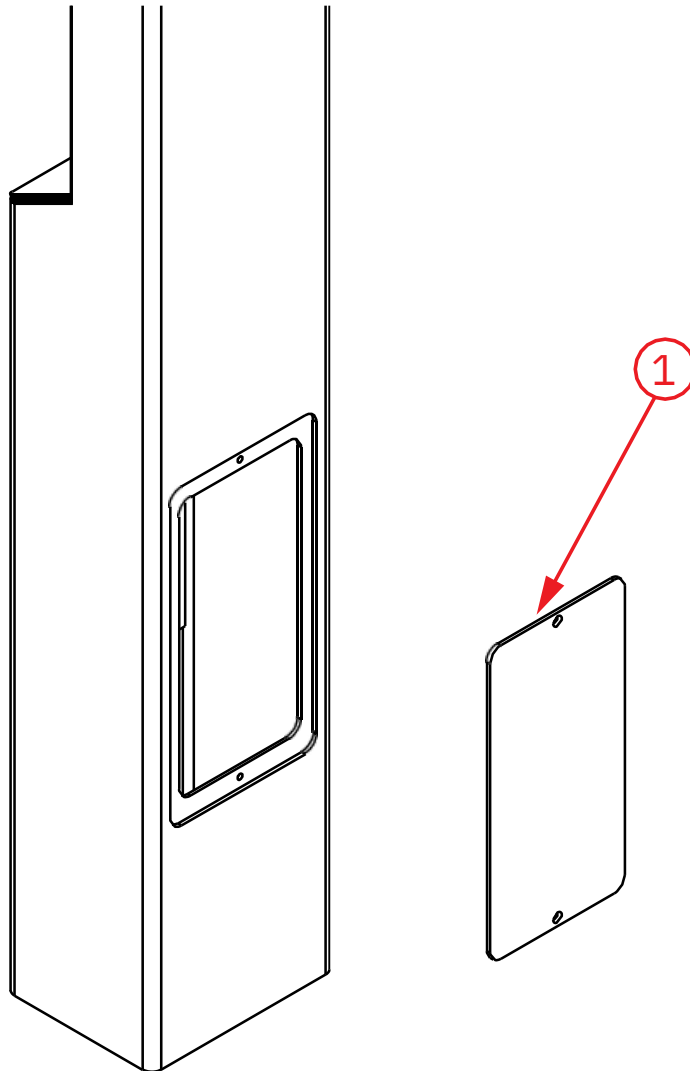

9 Maintenance Schedule

LEGEND

G Guard Tasks**T** Technician Tasks

DAILY OR WEEKLY

G Perform functional communications check.

- Action: Press Red Button
 - Strobe activates
 - Red LED "Call Placed" light turns on
 - Message plays
 - Call connects, green LED "Call Received" light turns on
 - Confirm conversation clarity with dispatch

MONTHLY OR QUARTERLY

G Visually check lighting functions:

- Faceplate light
- Beacon/Strobe

G Visually inspect unit for damage to:

- Faceplate
- Piezo Button
- Microphone
- Speaker

T Check Batteries:

- Functioning with full charge.
- Recharging fully, including NightCharge®/Solar Units (Note: Mid-to-late afternoon inspection is recommended)

IMPORTANT NOTE: Depending on the environment in which the batteries are installed, it is recommended that batteries for Solar & NightCharge® products are fully replaced every 2-3 years.

BIANNUALLY

T Remove access door and faceplate assembly to inspect the following:

- Ensure all electrical connections are secure
- Check all phone connections for corrosion (*If corroded, clean and coat with dielectric gel or replace*)
- Ensure all battery connections are tight and clean
- Verify no stains exist around gasket areas (stains indicate leaking & gasket should be replaced)
- Verify moisture weep hole on cabinet bottom is open and unobstructed
- Verify bottom of bollards are at least 1/2 inch above footing and free of obstructions (only applies to CB1, CB5, CB9, & CBRT units)

G Apply automotive paint sealant to unit exterior for protecting finish against environmental pollutants (Suggested products include Black Magic Wet Shine Liquid Wax, Nu Finish NFP-80, and 5 Star Shine)**G** Clean & coat exterior stainless steel cabinets with cleaner/polish (Suggested products include Chase Products' Champion Spray-on Stainless Steel Cleaner to help protect finish against environmental pollutants)**T** Visually confirm line-of-sight is still clear to base station (i.e., confirm that new tree growth, new building construction or other obstructions are not blocking view of base station)

UNIT SURFACE MAINTENANCE

The painted and stainless steel Code Blue models require periodic care to sustain their aesthetic appearance. Units located outdoors are vulnerable to harsh environmental conditions, including UV rays, acid rain, diesel fumes and airborne iron particles (i.e., dust) which over time may cause unit discoloring. To prevent pollutants developing harmful chemical reactions on Code Blue units, an appropriate surface maintenance schedule should be adhered to. The Surface Care Frequency table below provides general guidelines to assist in configuring a schedule. Please note that the frequency of care required to guard the Code Blue unit's surface from damage will also be dictated by local environmental characteristics.

LEGEND: POLLUTANTS LEVEL

Low	
Low/Moderate	
Moderate	
Moderate/High	
High	

SURFACE CARE FREQUENCY

	MONTHLY	BIMONTHLY	QUARTERLY	BIANNUAL	ANNUAL
Painted					
Stainless Steel					

See scheduled tasks under Biannually for suggested paint sealants or stainless steel cleaners.

AVERAGE COMPONENT LIFE

Component life is based on various mechanical, operational and environmental factors. Your local Code Blue reseller can assist you with a regularly scheduled maintenance program customized to your individual site requirements.

Code Blue strongly recommends contacting a local CB reseller to establish a proactive maintenance schedule.



10 Warranty

Code Blue Corporation provides a limited warranty on this product. Refer to your sales agreement to establish the terms. In addition, Code Blue's standard warranty language, as well as information regarding support for this product while under warranty, is available at www.codeblue.com/support

In Case of Breakdown

In case of system breakdown, discontinue use and contact Tech Support at:

technicalsupport@codeblue.com or call **800-205-7186, option 3.**

In Case of Abnormal Operation

If the unit emits smoke or an unusual smell, if water or other foreign material enters the enclosure, or if you drop the unit or damage the enclosure, power off the unit immediately and contact Code Blue Customer Service at:

customerservice@codeblue.com or call **800-205-7186, option 2.**



11 Download Information

Code Blue now has a centralized location where you can find installation, setup, information, configuration and operation instructions.

Admin Guides: www.codeblue.com/resources/guides

Firmware: www.codeblue.com/resources/firmware

Maintenance Tips: www.codeblue.com/support

Product Sheets: www.codeblue.com/resources/sheets

Specifications: www.codeblue.com/resources/specifications

These guides should contain all the information needed for your application. If further information is required, please contact customerservice@codeblue.com.

12 Legal & Regulatory Information

Legal Considerations

Video and audio surveillance can be regulated by laws that vary from country to country. Check the laws in your local region before using this product for surveillance purposes.

Liability

Every care has been taken in the preparation of this document. Please inform Code Blue Corporation of any inaccuracies or omissions. Code Blue cannot be held responsible for any technical or typographical errors and reserves the right to make changes to the product and manuals without prior notice. Code Blue makes no warranty of any kind with regard to the material contained within this document, including, but not limited to, the implied warranties of merchantability and fitness for a particular purpose. Code Blue shall not be liable or responsible for incidental or consequential damages in connection with the furnishing, performance or use of this material. This product is only to be used for its intended purpose.

Intellectual Property Rights

Code Blue Corporation has intellectual property rights relating to technology embodied in the product described in this document. This product contains open source code that also contains additional open source libraries.

Equipment Modifications

This equipment must be installed and used in strict accordance with the instructions given in the user documentation. This equipment contains no user-serviceable components. Unauthorized equipment changes or modifications will invalidate all applicable regulatory certifications and approvals.

Trademark Acknowledgments

Code Blue and Centry products are registered trademarks or trademark applications of Code Blue Corporation in various jurisdictions. All other company names and products are trademarks or registered trademarks of their respective companies.

Regulatory Information

Electromagnetic Compatibility (EMC)

This equipment has been designed and tested to fulfill applicable standards for:

- Radio Frequency emission when installed according to the instruction and used in the intended environment.
- Immunity to electrical and electromagnetic phenomenon when installed according to the instructions and used in its intended environments.

USA

This equipment has been tested using a shielded network cable (STP) and found to comply with the limits for a Class A digital device, pursuant to part 15 of the FCC Rules. These limits are designed to provide reasonable protection against harmful interference when the equipment is operated in a commercial environment. This equipment generates, uses and can radiate radio frequency energy and, if not installed and used in accordance with the instruction manual, may cause harmful interference to radio communications. Operation of this equipment in a residential area is likely to cause harmful interference in which case the user will be required to correct the interference at their own expense. The product shall be connected using a shielded network cable (STP) that is properly grounded.

Canada

This digital apparatus complies with CAN ICES-3 (Class A). The product shall be connected using a shielded network cable (STP) that is properly grounded.

Cet appareil numérique est conforme à la norme NMB ICES-3 (classe A). Le produit doit être connecté à l'aide d'un câble réseau blindé (STP) qui est correctement mis à la terre.

Disposal and Recycling

When this product has reached the end of its useful life, dispose of it according to local laws and regulations. For information about your nearest designated collection point, contact your local authority responsible for waste disposal. In accordance with local legislation, penalties may be applicable for incorrect disposal of this waste.

This guide should contain all the information needed for your application. If any further information is needed, please contact customerservice@codeblue.com.

Support

Should you require any technical assistance, please contact Code Blue.

Visit codeblue.com to:

- Download user documentation and software.
- Find answers to resolved problems in the FAQ database.

Report problems to Code Blue Technical Support via email at:

technicalsupport@codeblue.com or **800-205-7186**